

**Berry Paw Harvester - FPS Combo  
Heavy Duty Electric, Air Actuated  
Model BPHFPS-BPE-10430 (LH)  
BPHFPS-BPE-10431 (RH)**

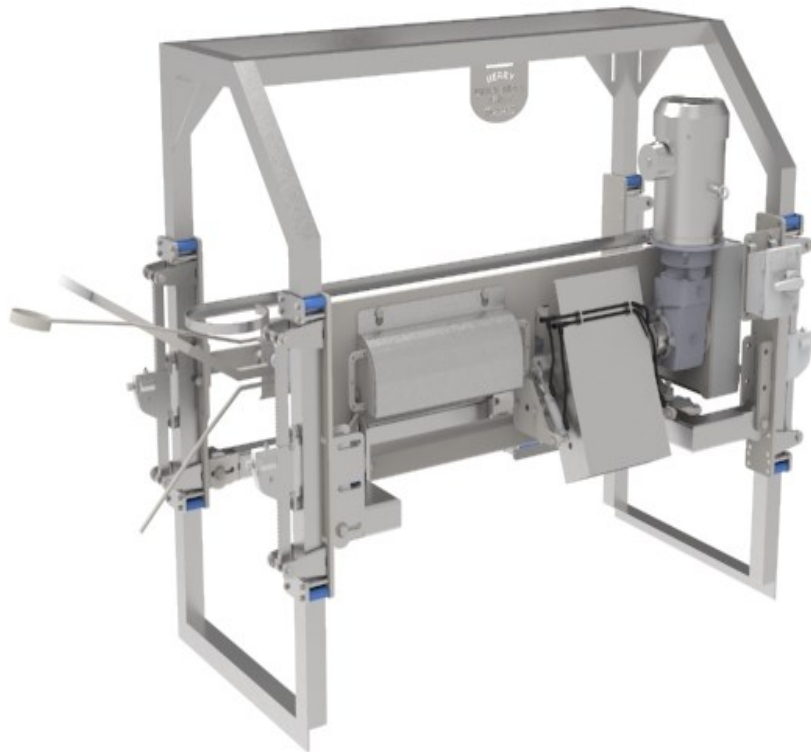

Automatically fed, electrically powered and designed to improve the appearance and harvest the paws of all size bird lots ; The Berry Paw Harvester / Foot Pad Scrubber Combo, from Berry Plumbing & Equipment will handle any line speed and provide a significant increase in yield.

# Berry Paw Harvester/Foot Pad Scrubber

246

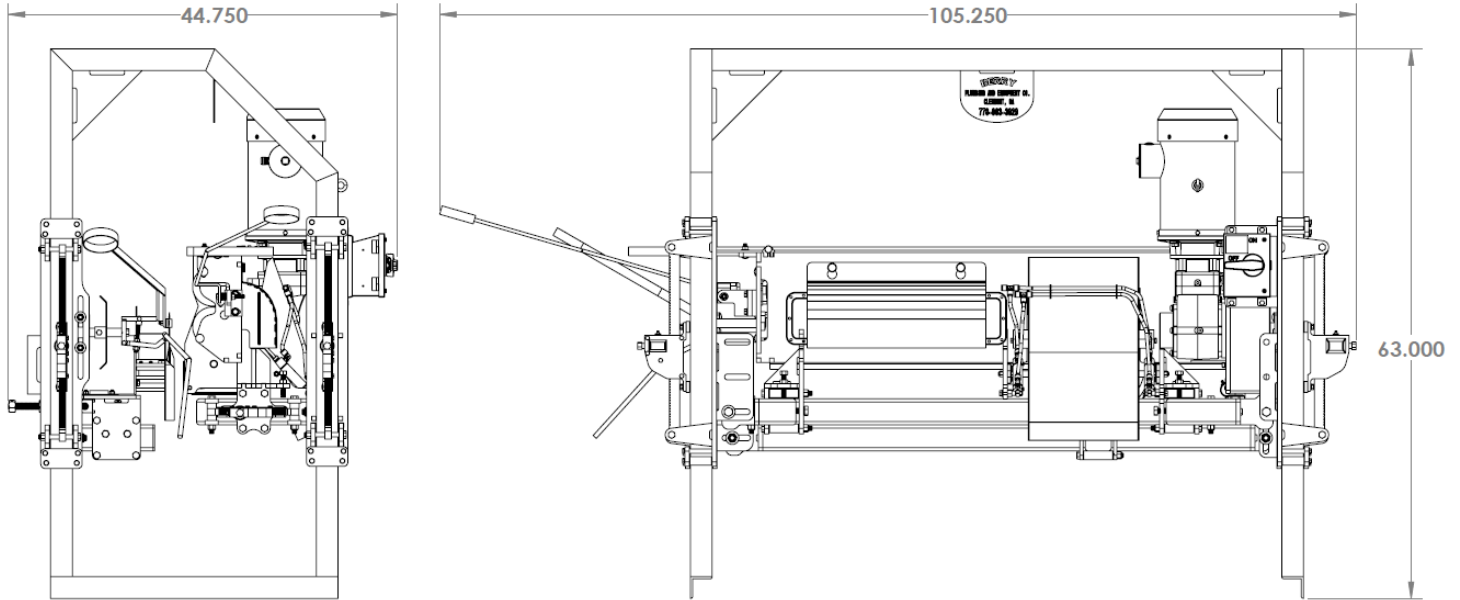

<b>POWER:</b>	1 Mtr @ 5 HP, 1750 RPM, 3 PHASE, 60 HZ, 208-230/460v, 12.8/6.4 FI amp 1 Mtr @ 1 HP, 1760 RPM, 3 PHASE, 60 HZ, 208-230/460V, 3.1/1.5 FI amp
<b>CAPACITY:</b>	DETERMINED BY LINE SPEED
<b>POSITION IN LINE:</b>	LAST ON KILL LINE
<b>FACING:</b>	DETERMINED FACING BACK OF BIRD
<b>HEIGHT:</b>	APPROXIMATELY 65"
<b>WIDTH:</b>	APPROXIMATELY 106"
<b>LENGTH:</b>	APPROXIMATELY 46"
<b>AIR:</b>	3/8 PUSH ON @ 80 PSI, AIR CONSUMPTION = 5 CFM (ONLY IF USING A REJECT CHUTE)

**Construction:**

The Berry Plumbing & Equipment **Electric Paw Harvester / Foot Pad Scrubber Combo** is constructed entirely of stainless steel and UHMW for durability and easy cleanup.

**Operation:**

**The Foot Pad Scrubber Combo** matches the speed of your Overhead Conveyor. Installed at the end of the Kill Line, the **Paw Harvester/ Foot Pad Scrubber Combo** features brushes that gently clean the foot and remove small ammonia burns, cuticle, and even fecal matter while perfectly positioning it in the shackle for a consistently straight cut at whatever length you require. The **Paw Harvester** blade then cleanly cuts and separates the paw from the knuckle, allowing for easy processing of any size paws.

**Yield:**

The Berry **Foot Pad Scrubber Combo** demonstrated a *significant increase* in yield when compared in tests to our competitors.

**Maintenance:**

With proper operation, regular cleaning and daily maintenance, the only other maintenance the **Paw Harvester / Foot Pad Scrubber Combo** requires is an occasional sharpening of the Paw Harvester blade.

The specifications as stated herein are the most current at the time of publication. However, consistent with our standard of continual product development, we reserve the right to change the design without notice or obligation to modify any equipment previously sold or delivered. 05/19/2022

**Berry Plumbing & Equipment**

6736 Cleveland Highway, Clermont Georgia 30527

Email: [tberry@berryequipment.net](mailto:tberry@berryequipment.net)

Phone: 770-983-3929 Toll Free Fax: 1-866-808-9957