

**Berry Burn Eliminator**  
**BBE-BPE-10027 (Left hand)**  
**or**  
**BBE-BPE-10030 (Right hand)**

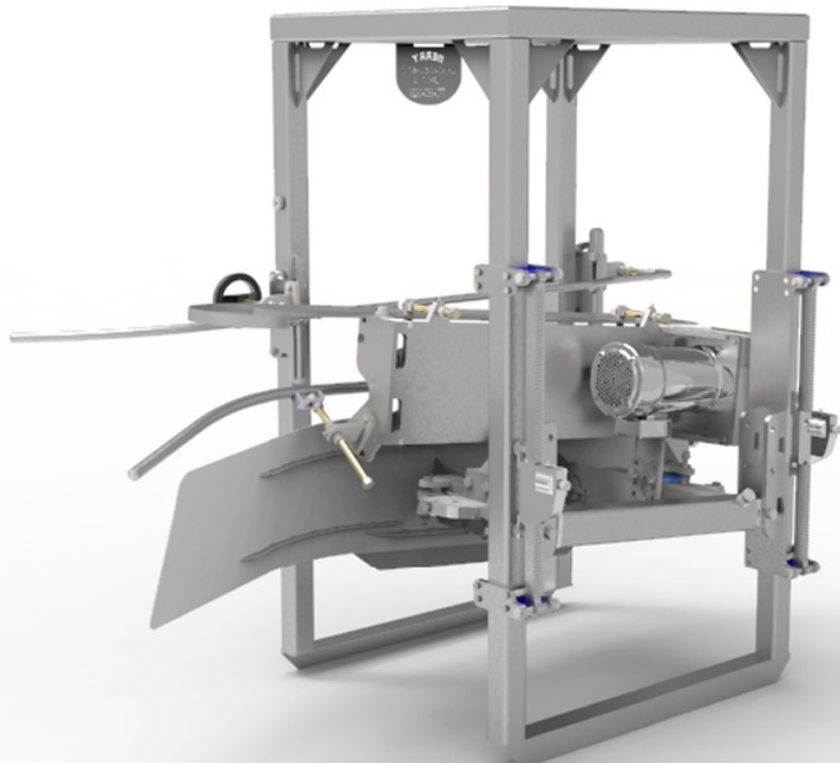

**Berry Burn Eliminator**

Berry Plumbing and Equipment's **Burn Eliminator, Model BBE-BPE-10027 (LH) or BBE-BPE-10030 (RH)**, is the latest piece in our paw line, now featuring the heavy duty components. Automatically fed, electrically powered and designed to remove the burns off the paws of all size bird's lots; the Berry Burn Eliminator, from Berry Plumbing & Equipment will handle any line speed.

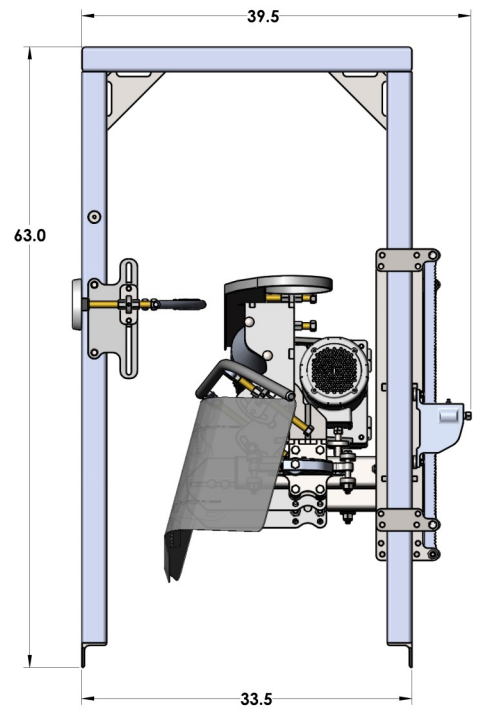
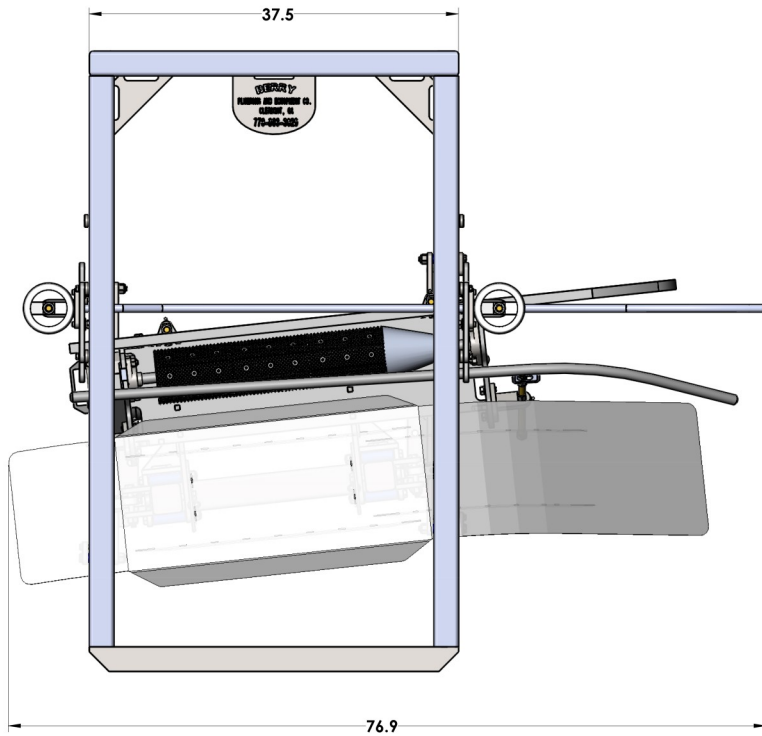

Left Hand Model Shown

<b>POWER:</b>	1 hp, 60 hz, 3 ph., 1200 rpm, 208-230/460v
<b>CAPACITY:</b>	Determined by line speed
<b>POSITION IN LINE:</b>	After the Feather Pickers
<b>FACING:</b>	Determined facing the back of the bird ( Available in a Left or Right hand model machine )
<b>HEIGHT:</b>	63"
<b>WIDTH:</b>	76.90"
<b>DEPTH:</b>	39.50"

## Berry Plumbing & Equipment

6736 Cleveland Highway, Clermont Georgia 30527  
 Email: [tberry@berryequipment.net](mailto:tberry@berryequipment.net)  
 Phone: 770-983-3929 Toll Free Fax: 1-866-808-9957

**Construction:**

The Berry Plumbing & Equipment **Burn Eliminator** is constructed entirely of stainless steel for durability and easy cleanup.

**Operation:**

Automatically fed and electrically powered, the Berry **Burn Eliminator** matches the speed of your Overhead Conveyor. Installed after the Feather Picker the **Burn Eliminator** features three Burn Eliminator Scrapers that assist in the removal of ammonia burns.

**Preventative Maintenance:**

With proper operation and regular cleaning, the only other preventative maintenance the **Burn Eliminator** requires is lubrication of bearings and monitoring of the Burn Eliminator Scraper Blades for Replacement.

This is a sampling of the paws appearance after being processed through the Berry Burn Eliminator



The specifications as stated herein are the most current at the time of publication. However, consistent with our standard of continual product development, we reserve the right to change the design without notice or obligation to modify any equipment previously sold or delivered. 01/17/2012

**Berry Plumbing & Equipment**

6736 Cleveland Highway, Clermont Georgia 30527

Email: [tberry@berryequipment.net](mailto:tberry@berryequipment.net)

Phone: 770-983-3929 Toll Free Fax: 1-866-808-9957