

Model B-PH-EXT-48-LH/RH

US Patent # 6283848 B1



Automatically fed, hydraulically powered and designed to remove the paws of all size birds lots, **Model B-PH-EXT-48-LH/RH Paw Harvester** from Berry Plumbing & Equipment will handle any line speed and provide a significant increase in yield.

Berry Paw Harvester Ext.

WATER:	N/A
HYDRALIC FLIUD:	22 G.P.M. @ 950 P.S.I.
CAPACITY:	DETERMINED BY LINE SPEED
POSITION IN LINE:	LAST ON KILL LINE
FACING:	DETERMIND FACING BACK OF BIRD (AVAILABLE IN LEFT HAND OR RIGHT HAND MACHINE)
HEIGHT:	DETERMINED BY SHACKLE SETUP AND BIRD SIZE (Approx 62")
WIDTH:	APPROX 36"
LENGTH:	APPROX 103"

Construction:

The Berry Plumbing & Equipment **Paw Harvester Extended** is constructed entirely of stainless steel and UHMW for durability and easy cleanup.

Maintenance:

Regular cleaning of machine, along with checking hydraulic oil in motors, bearings for lubrication, sharpening of blade, normal wear & tear of other parts such as the teflon guide bar.

Options:

Berry Plumbing & Equipment offers a **Hydraulic Power Unit** for operation of the **B-PH-EXT-48-LH/RH**.

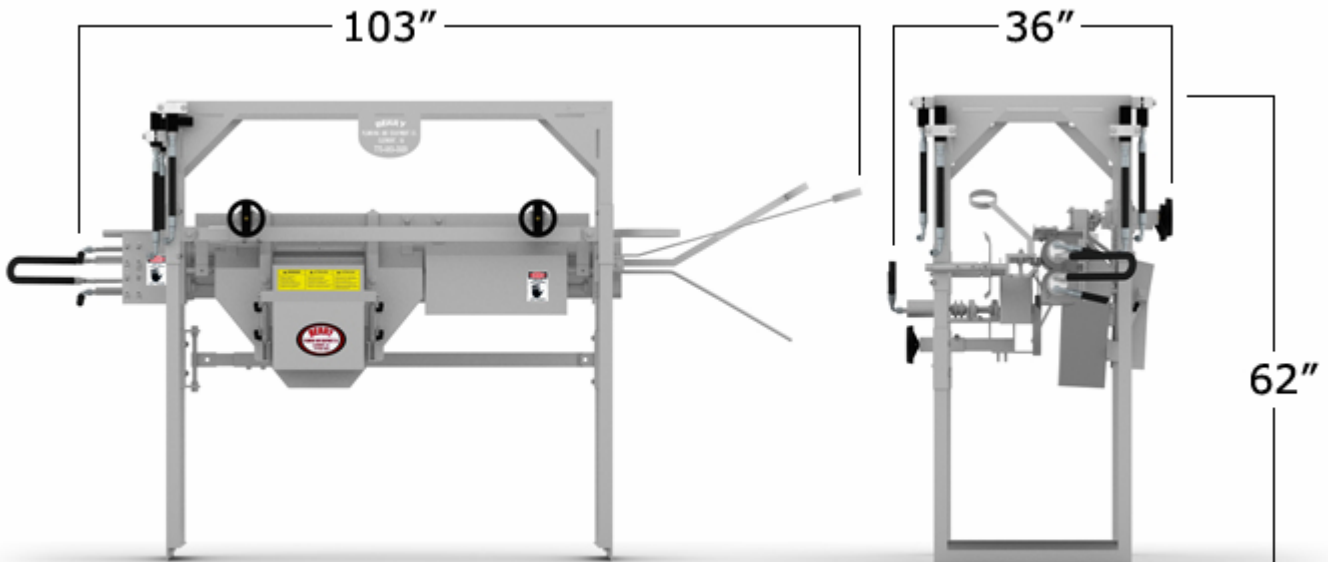

Hydraulic Brush Motors:

2 per machine

3 cubic inches

1000 psi @ 5.5 gpm

RPM = 377

Torque = 339 in/lb

- Port A of top motor—fluid in from plant
- Port B of top motor connects to port B of bottom motor
- Port A of bottom motor—fluid return to plant

Hydraulic Blade Motors:

1 per machine

1.21 cubic inch

1000 psi @ 5.5 gpm

RPM = 500 max

Torque = 137 in/lb

- **Do NOT allow blade motor to exceed 500 rpm for safety precautions. The Berry Paw Harvester is equipped with a flow control valve for the purpose of maintaining the blade motor at a steady 500 rpm.**

The specifications as stated herein are the most current at the time of publication. However, consistent with our standard of continual product development, we reserve the right to change the design without notice or obligation to modify any equipment previously sold or delivered. 07/26/2009

Berry Plumbing & Equipment

6736 Cleveland Highway, Clermont Georgia 30527

Email: tberry@berryequipment.net

Phone: 770-983-3929 Toll Free Fax: 1-866-808-9957