

Model B-PH RH/LH

US Patent # 6283848 B1



Berry Paw Harvester

Automatically fed, hydraulically powered and designed to remove the paws of all size birds lots, Model **B-PH-RH/LH Paw Harvester** from Berry Plumbing & Equipment will handle any line speed and provide a significant increase in yield.

Berry Paw Harvester

WATER:	N/A
HYDRALIC FLIUD:	22 G.P.M. @ 950 P.S.I.
CAPACITY:	DETERMINED BY LINE SPEED
POSITION IN LINE:	LAST ON KILL LINE
FACING:	DETERMIND FACING BACK OF BIRD (AVAILABLE IN LEFT HAND OR RIGHT HAND MACHINE)
HEIGHT:	DETERMINED BY SHACKLE SETUP AND BIRD SIZE (Approx 62")
WIDTH:	APPROX 82"
DEPTH:	APPROX 40"

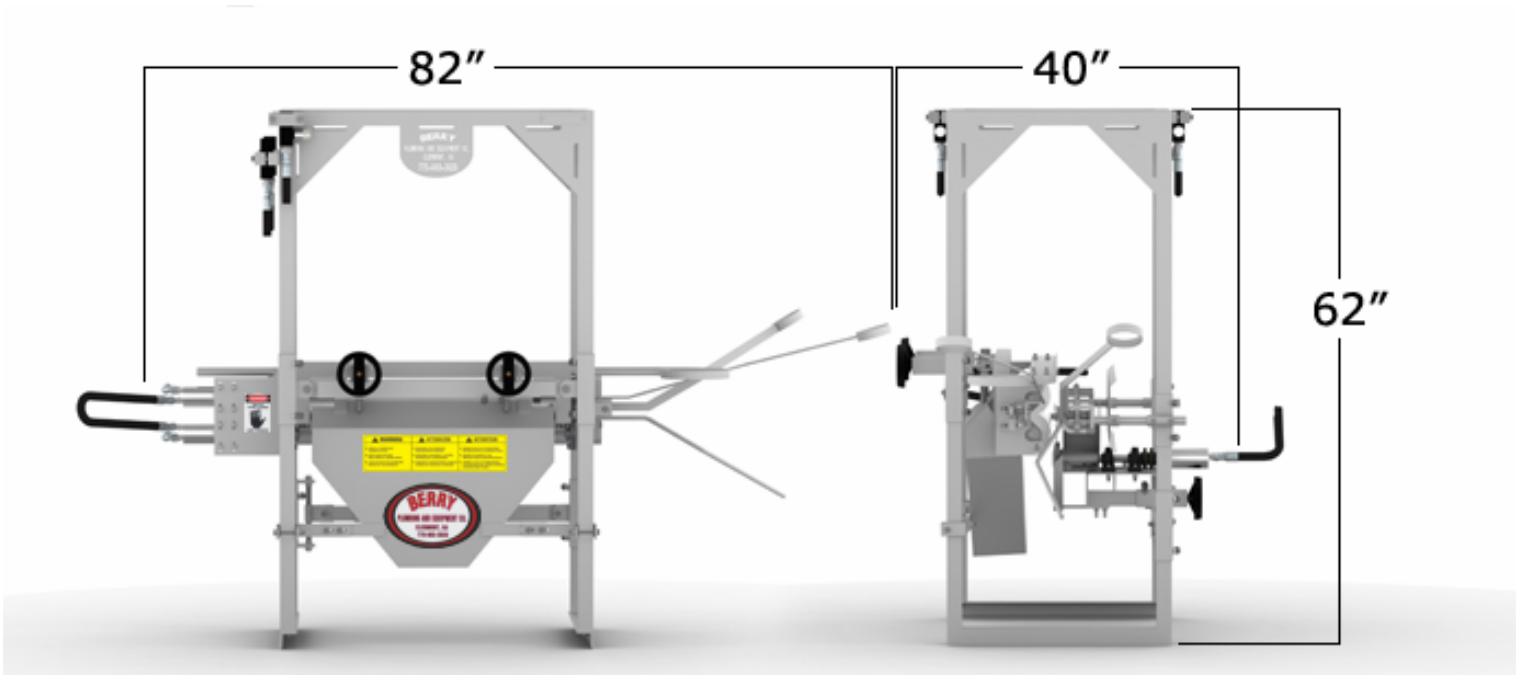

Hydraulic Brush Motors:

2 per machine
3 cubic inches
1000 psi @ 5.5 gpm
RPM = 377
Torque = 339 in/lb

- Port A of top motor—fluid in from plant
- Port B of top motor connects to port B of bottom motor
- Port A of bottom motor—fluid return to plant

Hydraulic Blade Motors:

1 per machine
1.21 cubic inch
1000 psi @ 5.5 gpm
RPM = 500 max
Torque = 137 in/lb

- **Do NOT allow blade motor to exceed 500 rpm for safety precautions. The Berry Paw Harvester is quipped with a flow control valve for the purpose of maintaining the blade motor at a steady 500 rpm.**

Construction:

The Berry Plumbing & Equipment **Paw Harvester Model B-PH-RH/LH** is constructed entirely of stainless steel and UHMW for durability and easy cleanup.

Operation:

Automatically fed and hydraulically powered, the Berry **Paw Harvester Model B-PH-RH/LH** matches the speed of your Overhead Conveyor. Installed at the end of the Kill Line, the **Paw Harvester** features brushes that gently clean the foot while perfectly positioning it in the shackle for a consistently straight cut at whatever length you require. The **Paw Harvester** blade then cleanly cuts and separates the paw from the knuckle, allowing for easy processing of any size paws.

Yield:

The Berry **Model B-PH-RH/LH** demonstrated a *significant increase* in yield when compared in tests to our competitors.

Maintenance:

With proper operation, regular cleaning and lubrication of bearings, the only other maintenance the **Model B-PH-RH/LH Paw Harvester** requires is an occasional sharpening of the Paw Harvester blade.

Options:

Berry Plumbing & Equipment offers a **Hydraulic Power Unit** for operation of the **B-PH-RH/LH**. Also the **Berry Paw Harvester with Reject Chute and Air Control Box** is available for the option of whole paw harvesting.

The specifications as stated herein are the most current at the time of publication. However, consistent with our standard of continual product development, we reserve the right to change the design without notice or obligation to modify any equipment previously sold or delivered. 12/31/2000

Berry Plumbing & Equipment

6736 Cleveland Highway, Clermont Georgia 30527

Email: tberry@berryequipment.net

Phone: 770-983-3929 Toll Free Fax: 1-866-808-9957