

Model B-WFH

US Patent # 6283848 B1

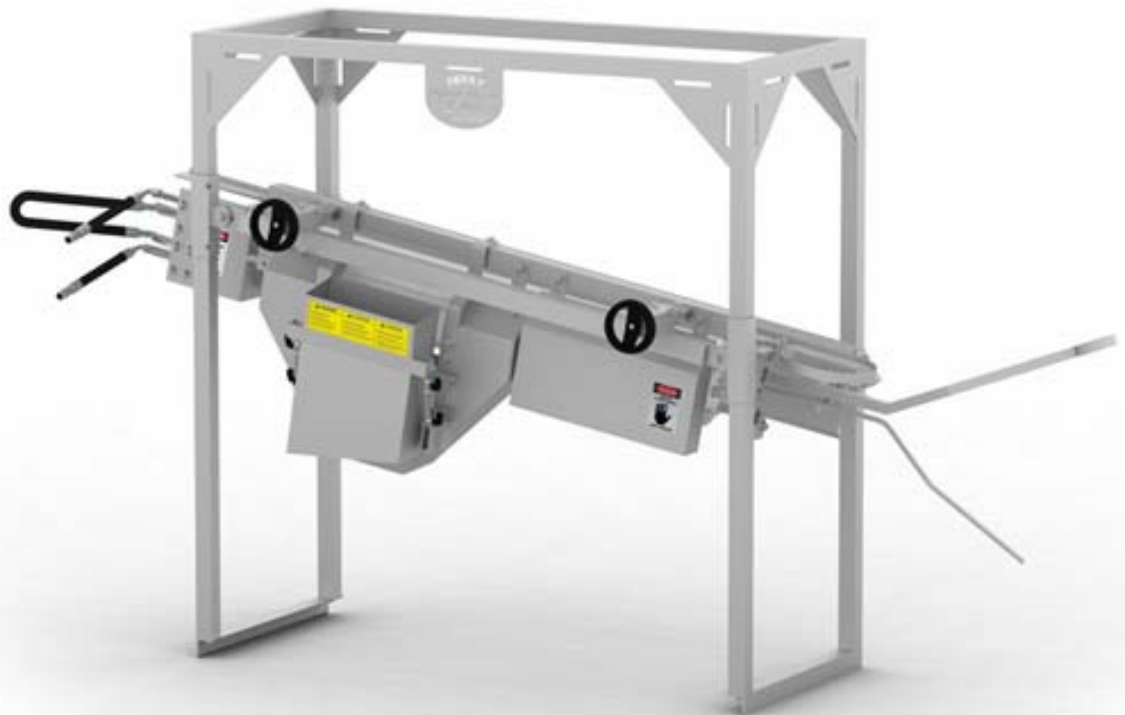

As customer demand changes, **Berry Plumbing & Equipment** is leading the industry in Paw Harvesting with our new **Berry Whole Foot Harvester**. Now the customer can harvest the entire paw with knuckle. This machine is compatible with the Berry Paw Recovery System.

WATER:	N/A
HYDRALIC FLIUD:	5.5 G.P.M. PER MOTOR @ approx 1000 PSI
CAPACITY:	DETERMINED BY LINE SPEED
POSITION IN LINE:	LAST ON KILL LINE
FACING:	DETERMINED FACING BACK OF BIRD (AVAILABLE IN LEFT HAND OR RIGHT HAND MACHINE)
HEIGHT:	DETERMINED BY SHACKLE SETUP AND BIRD SIZE (Approx 62")
DEPTH:	APPROX 33"
WIDTH:	APPROX 101"

Construction: The Berry Plumbing & Equipment **Whole Foot Harvester** is constructed entirely of stainless steel, aluminum, and UHMW for durability and easy cleanup.

Operation: Automatically fed and hydraulically powered, the Berry Whole Foot Harvester **Model B-WFH** matches the speed of your Overhead Line. Installed at the end of the Kill Line, the Whole Foot Harvester features brushes that gently pull the foot to allow harvesting of the whole foot with knuckle.

Maintenance: With proper operation, regular cleaning and lubrication of bearings, the only other maintenance the **Model B-WFH Whole Foot Harvester** requires is adjustment of guidebars and replacement of worn consumable parts.

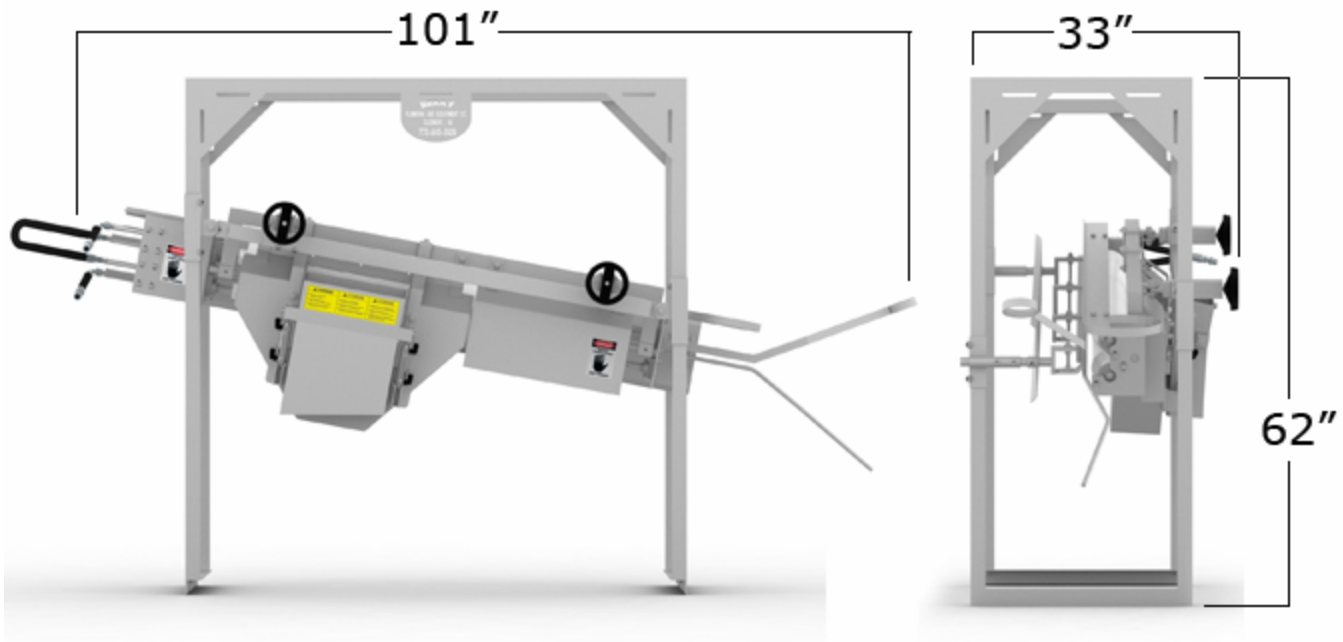

Options:

Berry Plumbing & Equipment offers a **Hydraulic Power Unit** for operation of the **B-WFH**.