

Berry Wing Machine

Model B-WM-1



Model **B-WM-1** is designed to give you quality cuts on the three sections of the wing leaving you with top grade maximum yield on the drumettes, flats (2nd portion) , and tips. The unique 3 piece wing wheel allows customers to purchase only the worn out section of the wheel, rather than purchasing and replacing an entire wheel.

Construction:

The Berry Plumbing & Equipment **Model B-WM-1 Wing Machine** is constructed entirely of stainless steel and Nylon for durability and easy cleanup.

Cleaning/Washdown:

This machine should be cleaned thoroughly at the end of each shift (minimum) or times set forth by plant recommendations. Use only USDA approved detergent and high pressure, hot water. Rinse thoroughly.

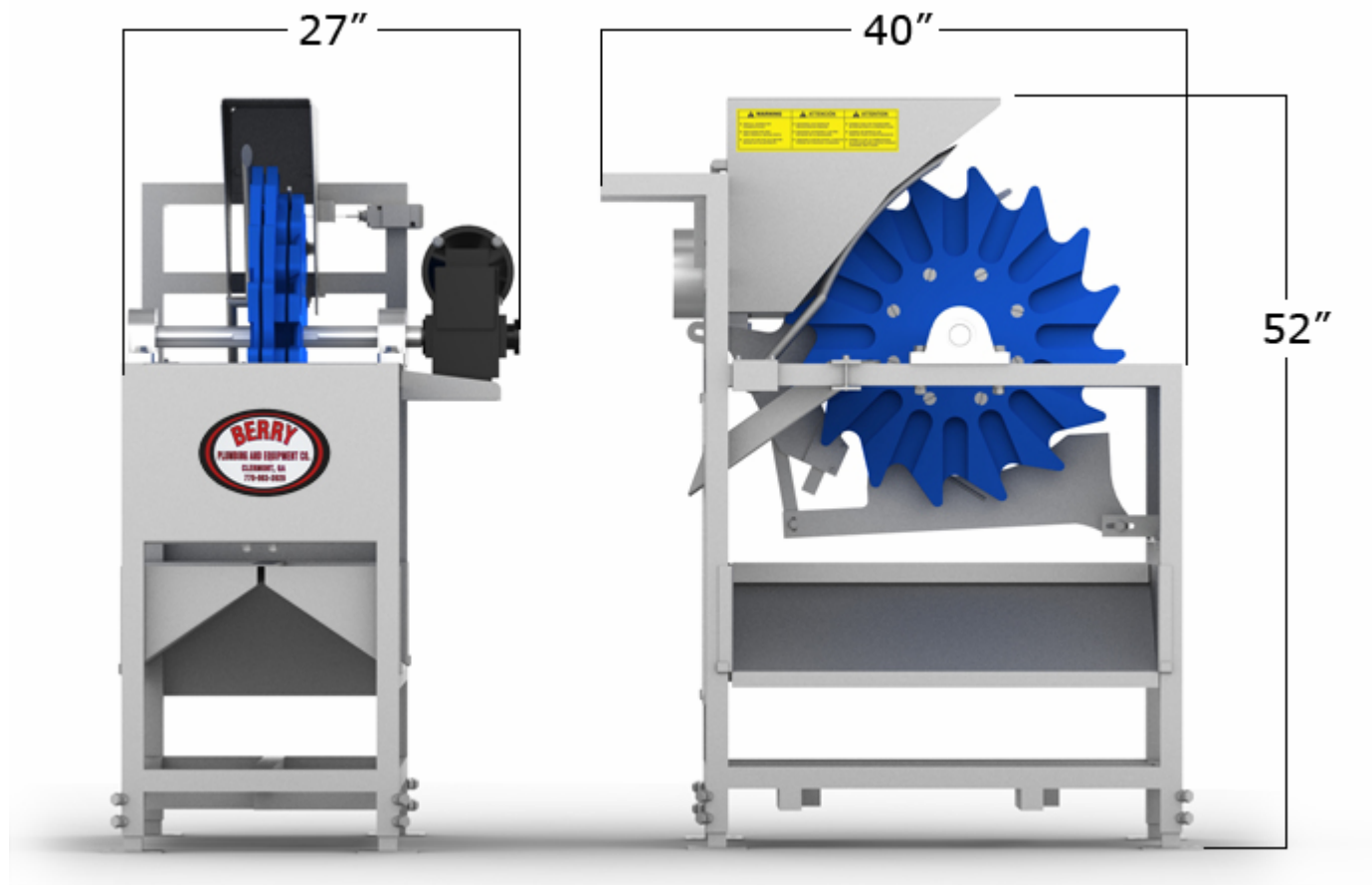

ELECTRICITY:	(1) 1 HP ELECTRIC MOTOR, 3 PHASE
GEARBOX:	(1) 300 TO 1 RATIO
CAPACITY:	90 WINGS PER MINUTE (dependent upon operator)
HEIGHT:	APPROXIMATELY 52"
WIDTH:	APPROXIMATELY 40"
LENGTH:	APPROXIMATELY 27"

The specifications as stated herein are the most current at the time of publication. However, consistent with our standard of continual product development, we reserve the right to change the design without notice or obligation to modify any equipment previously sold or delivered. 12/31/2000

Berry Plumbing & Equipment
6736 Cleveland Highway, Clermont Georgia 30527
Email: tberry@berryequipment.net
Phone: 770-983-3929 Toll Free Fax: 1-866-808-9957