

## **Model B-FPS-HDH-G2**

**US Patent # 7625270 B2**

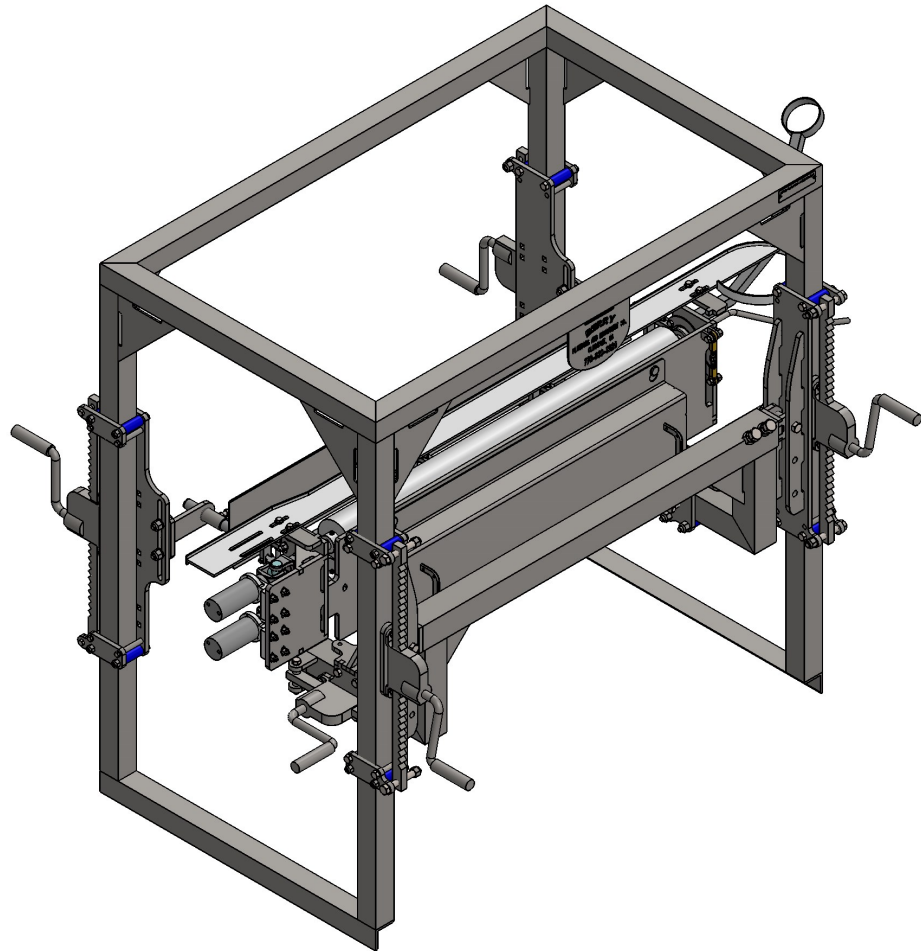

The Berry Plumbing and Equipment **Model B-FPS-HDH-G2, Foot Pad Scrubber** is the latest piece in our paw line, now featuring the heavy duty components. Automatically fed, hydraulically powered and designed to improve the appearance of the paws of all size bird's lots; the Berry Foot Pad Scrubber Heavy Duty Hydraulic, Model B-FPS-HDH-G2 from Berry Plumbing & Equipment will handle any line speed.

Berry Foot Pad Scrubber HDH-G2

## Berry Foot Pad Scrubber Heavy Duty Hydraulic-G2

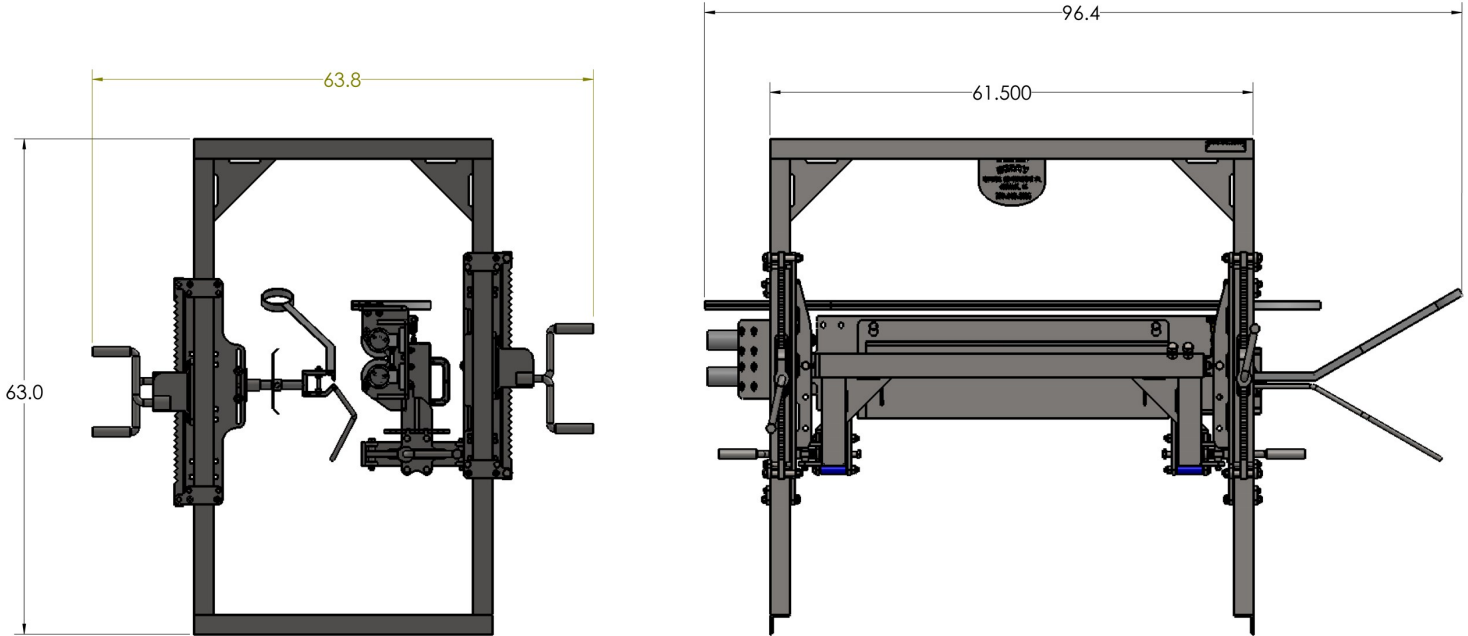

<b>HYDRAULICS:</b>	15 GPM, 950 PSI
<b>AIR:</b>	3/8 PUSHON @ 80 PSI
<b>CAPACITY:</b>	DETERMINED BY LINE SPEED
<b>POSITION IN LINE:</b>	After the Dip Tank and prior to the Paw Harvester
<b>FACING:</b>	DETERMINED FACING BACK OF BIRD (AVAILABLE IN LEFT HAND OR RIGHT HAND MACHINE)
<b>HEIGHT:</b>	APPROXIMATELY 63"
<b>WIDTH:</b>	APPROXIMATELY 95"
<b>DEPTH:</b>	APPROXIMATELY 64"

## Berry Foot Pad Scrubber Heavy Duty Hydraulic-G2

### Construction:

The Berry Plumbing & Equipment **Foot Pad Scrubber Model B-FPS-HDH-G2** is constructed entirely of stainless steel and UHMW for durability and easy cleanup.

### Operation:

Automatically fed and hydraulically powered, the Berry **Foot Pad Scrubber Model B-FPS-HDH-G2** matches the speed of your Overhead Conveyor. Installed after the Berry Dip Tank, the **Foot Pad Scrubber** features two brushes that massage the foot, assisting in removal of ammonia burns, cuticle, and even fecal matter.

### Maintenance:

With proper operation and regular cleaning, the only other maintenance the **Foot Pad Scrubber Model B-FPS-HDH-G2** requires is lubrication of bearings.

### Options:

## Berry Ammonia Paw Scraper

The Ammonia Paw Scraper is designed for the **Berry** Foot Pad Scrubbers. The APS attachment fits on a specially designed brush and shaft and is positioned as the top brush on the **Berry** Foot Pad Scrubbers. The ammonia paw scraper attachment goes on the exit end to aid in the removal of ammonia burns from the paws.



The specifications as stated herein are the most current at the time of publication. However, consistent with our standard of continual product development, we reserve the right to change the design without notice or obligation to modify any equipment previously sold or delivered. 01/17/2012

### **Berry Plumbing & Equipment**

6736 Cleveland Highway, Clermont Georgia 30527

Email: [tberry@berryequipment.net](mailto:tberry@berryequipment.net)

Phone: 770-983-3929 Toll Free Fax: 1-866-808-9957