

**Model BFP-BPE-10329 (RH)
BFP-BPE-10330 (LH)**

Berry Foot Picker

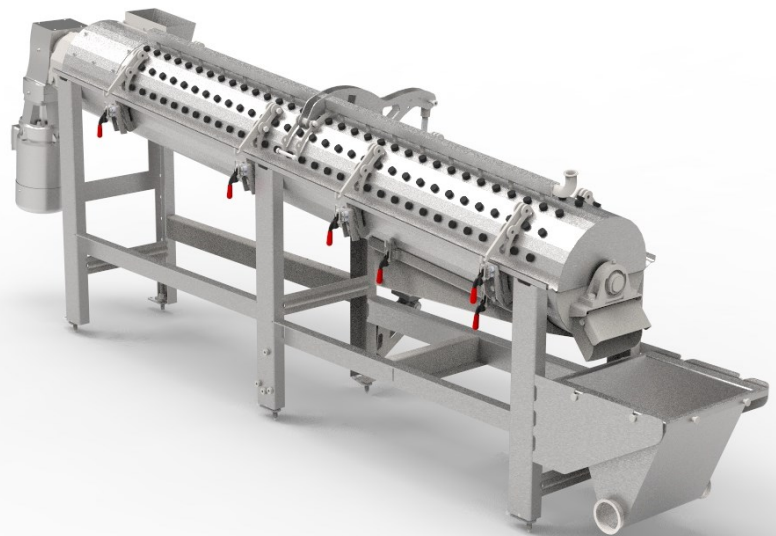

The Berry Plumbing & Equipment **Foot Picker** is constructed entirely of stainless steel, aluminum, and rubber for durability and easy cleanup. Paws from your Berry Paw Harvester are transported to the Berry **Foot Picker** where they are fed into the infeed chute. The paws fall into a picking chamber where a rotating system of fingers gently push them against a bank of fixed fingers above while moving them steadily downward to the discharge chute where they emerge clean and cuticle free.

Berry Foot Picker Model BFP-BPE-10239 (RH) & BFP-BPE-10330 (LH)

233

Construction:

The frame and cabinet of the Berry Plumbing & Equipment **Foot Picker** is constructed entirely of stainless steel for durability and easy cleanup. Picking fingers are made of rubber.

Operation:

Paws are deposited into the **Foot Picker** from the **Paw Harvester**. Here they are gently cleaned as they traverse a system of fixed and rotating fingers and pressurized water which remove all remaining cuticle from the paws. Waste falls from the **Foot Picker** through the perforated basin into a catch pan under the picker. Paws emerge thoroughly cleaned with very little damage to the product.

Maintenance:

Berry Plumbing & Equipment Company designers and technicians have taken great care in assuring that the **Foot Picker** is manufactured with smooth rounded surfaces and easily removable covers to make thorough clean up easy for cleaning personnel. Maintenance required is cleaning, regular greasing of bearings and chains and checking for worn fingers.

WATER:	1 1/2" CONNECTION — APPROX 28.8 GPM @ 40 PSI APPROXIMATELY 120 to 160°*
ELECTRICITY:	10 H.P. ELECTRIC MOTOR
ROTATING PICKER ASSEMBLY SPEED:	480 RPM
CAPACITY:	APPROX 560 PIECES PER MINUTE
POSITION IN LINE:	AFTER PAW HARVESTER
HEIGHT:	Approx. 56"
WIDTH:	Approx. 39.50"
OVERALL LENGTH:	Approx. 165"

*Water temperature ranges are suggestions only. As every plant is set up differently, there are many variables to be considered to find the best temperature to give you desired results. Condition of flock, line speed, and bird size are just a few of the factors to be concerned with when working to find that ideal temperature. As those factors change, you should watch your temperature settings and adjust accordingly.

Berry Foot Picker Model BFP-BPE-10239 (RH) & BFP-BPE-10330 (LH)

233

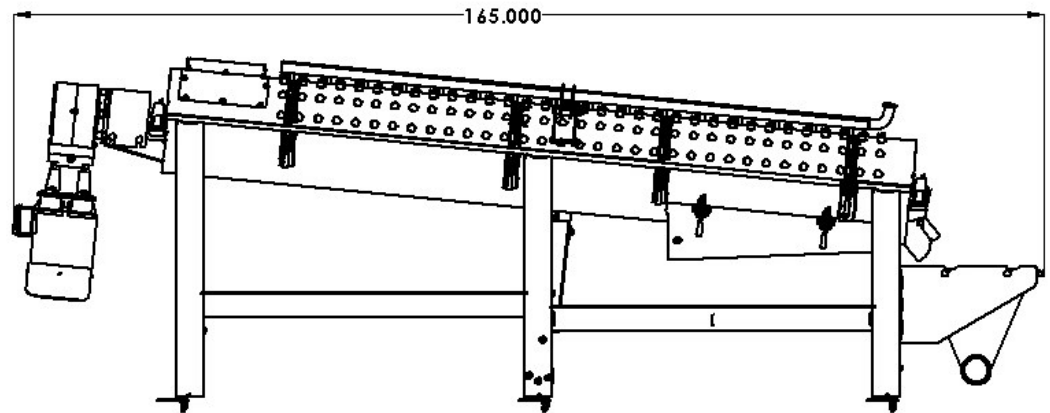
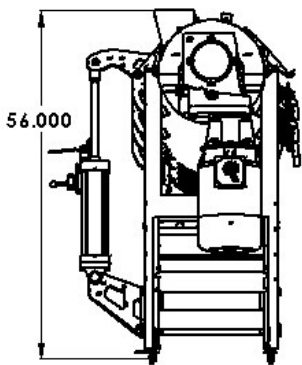
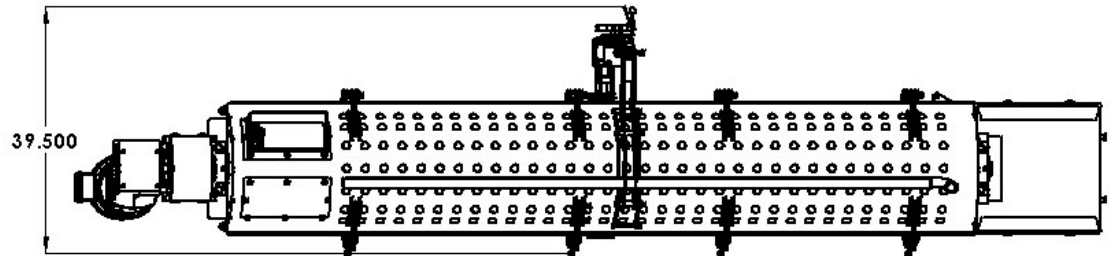

The specifications as stated herein are the most current at the time of publication. However, consistent with our standard of continual product development, we reserve the right to change the design without notice or obligation to modify any equipment previously sold or delivered.

11/03/2021

Berry Plumbing & Equipment
6736 Cleveland Highway, Clermont Georgia 30527
Email: tberry@berryequipment.net
Phone: 770-983-3929 Toll Free Fax: 1-866-808-9957