

Model B-PH-FPS-HDH

US Patent # 6283848 B1

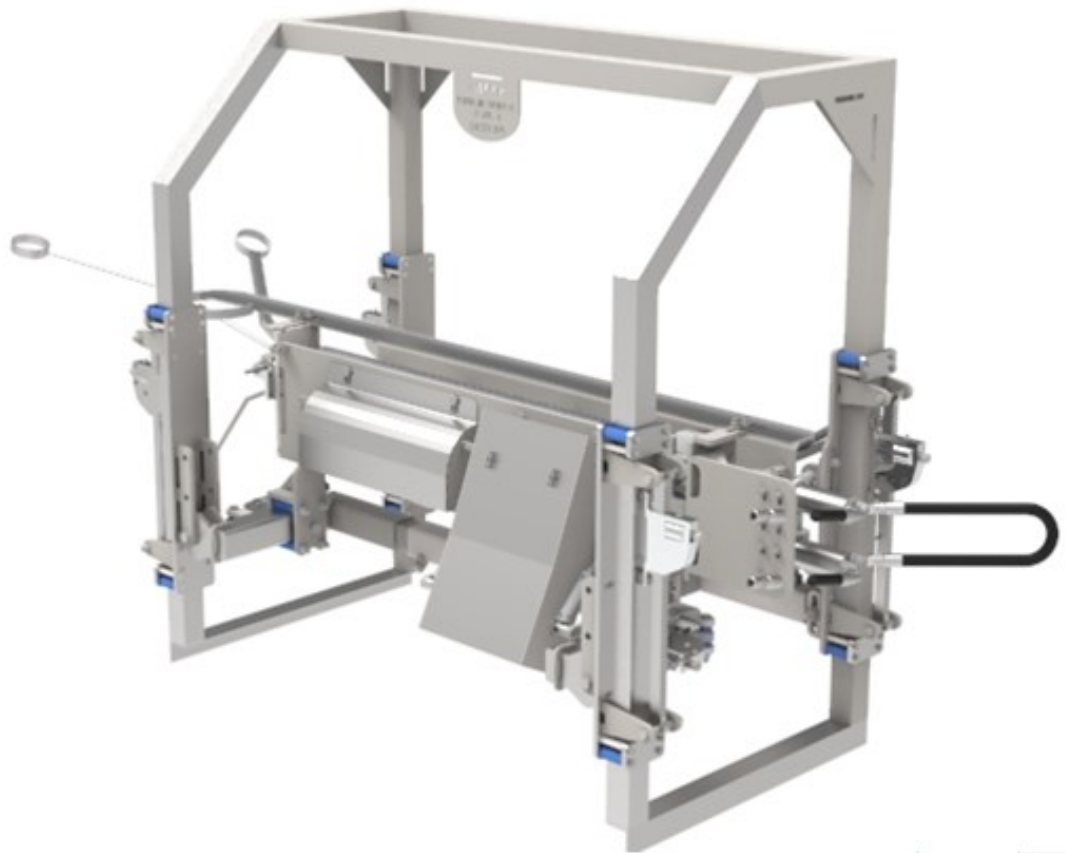

Automatically fed, hydraulically powered and designed to improve the appearance and harvest the paws of all size bird lots ; The Berry Paw Harvester / Foot Pad Scrubber Combo from Berry Plumbing & Equipment will handle any line speed and provide a significant increase in yield.

**Berry Paw Harvester / FPS Combo Heavy
Duty Hydraulic**

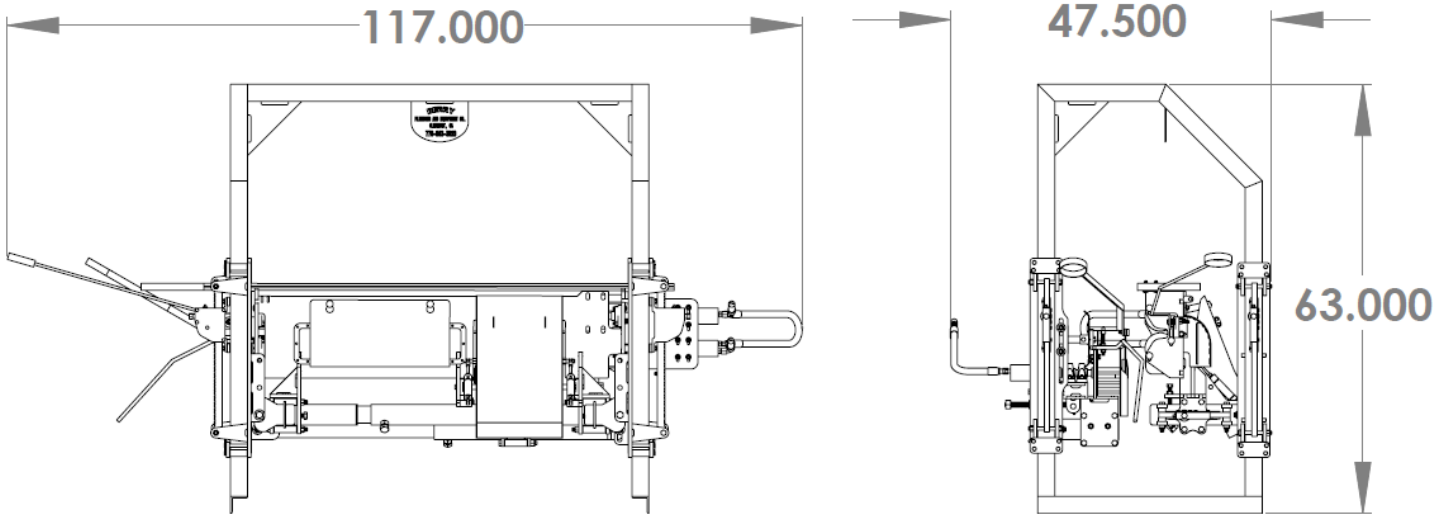

BRUSH MOTOR:	15 GPM
BLADE MOTOR	5.5 GPM
CAPACITY:	DETERMINED BY LINE SPEED
POSITION IN LINE:	LAST ON KILL LINE
FACING:	DETERMINED FACING BACK OF BIRD
HEIGHT:	APPROXIMATELY 63"
WIDTH:	APPROXIMATELY 117"
LENGTH:	APPROXIMATELY 46"
PRESSURE:	950 PSI
AIR:	3/8 PUSH ON @ 80 PSI, AIR CONSUMPTION = 5 CFM (ONLY IF USING A REJECT CHUTE)

Construction:

The Berry Plumbing & Equipment **Hydraulic Paw Harvester / Foot Pad Scrubber Combo** is constructed entirely of stainless steel and UHMW for durability and easy cleanup.

Operation:

The Model matches the speed of your Overhead Conveyor. Installed at the end of the Kill Line, the **Paw Harvester/ Foot Pad Scrubber Combo** features brushes that gently clean the foot and remove small ammonia burns, cuticle, and even fecal matter while perfectly positioning it in the shackle for a consistently straight cut at whatever length you require. The **Paw Harvester** blade then cleanly cuts and separates the paw from the knuckle, allowing for easy processing of any size paws.

Yield:

The Berry **Paw Harvester/ Foot Pad Scrubber Combo** demonstrated a *significant increase* in yield when compared in tests to our competitors.

Maintenance:

With proper operation, regular cleaning and daily maintenance, the only other maintenance the **Paw Harvester / Foot Pad Scrubber Combo** requires is an occasional sharpening of the Paw Harvester blade.

The specifications as stated herein are the most current at the time of publication. However, consistent with our standard of continual product development, we reserve the right to change the design without notice or obligation to modify any equipment previously sold or delivered. 09/28/2012

Berry Plumbing & Equipment

6736 Cleveland Highway, Clermont Georgia 30527

Email: tberry@berryequipment.net

Phone: 770-983-3929 Toll Free Fax: 1-866-808-9957