

## Model B-CWW-1-SS-10

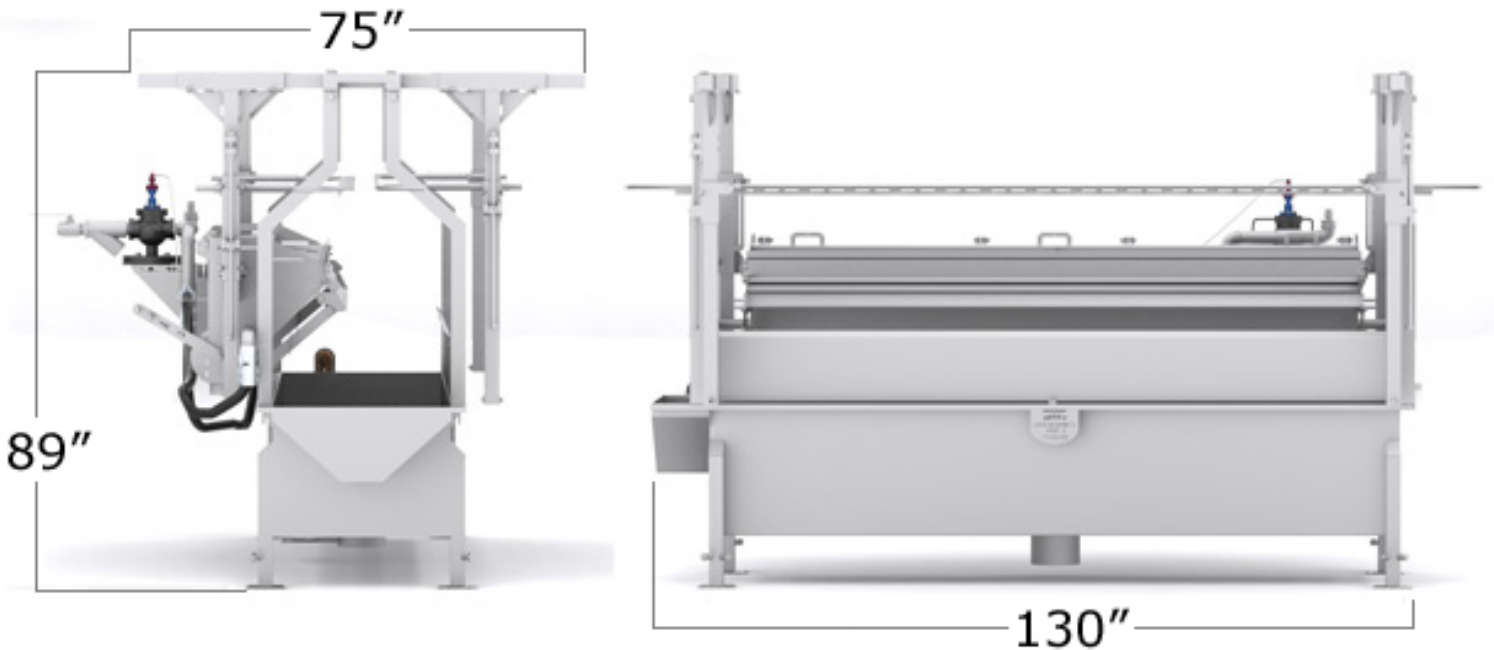

The Model **B-CW-1-SS Berry Single Sided Cascading Waterfall for Wings** will enhance yield throughout the slaughter process by allowing customers to reduce the temperatures of the Bird Scalders without sacrificing wing quality. The cascade of water is directed toward the back of the birds and across the wings. This method directly scalds the wings to aid in removal of the cuticle and feathers.

## Berry Single Sided Cascading Waterfall - Model B-CW-1-SS



WATER RESERVOIR	HOT WATER FILL: 2" NPT DRAIN: 3" NPT
WATER TANK	HOT WATER FILL: 2" NPT (25 PSI MAX - REGULATE DOWN) DRAIN: 4" FERRULE
STEAM	CONNECTION: 1 1/4" NPT PRESSURE: 125 PSI MAX POUNDS OF STEAM PER HOUR: 624
PUMP / MOTOR	600 GPM @ 15 PSI 15 HP, 1750 RPM, 3 PH, 60 HZ, 380V, 254TC, FULL LOAD AMP 18.5
CAPACITY	DEPENDENT ON LINE SPEED
HEIGHT	APPROX 89" ( DETERMINED BY SHACKLE SETUP AND BIRD SIZE )
WIDTH	APPROX 75"
LENGTH	APPROX 130"

The specifications as stated herein are the most current at the time of publication. However, consistent with our standard of continual product development, we reserve the right to change the design without notice or obligation to modify any equipment previously sold or delivered. 01/17/2012

### **Berry Plumbing & Equipment**

6736 Cleveland Highway, Clermont Georgia 30527

Email: [tberry@berryequipment.net](mailto:tberry@berryequipment.net)

Phone: 770-983-3929 Toll Free Fax: 1-866-808-9957

## Berry Single Sided Cascading Waterfall - Model B-CW-1-SS

### **Construction:**

The **Berry CW-1-SS** is designed for maximum safety and ease of operation. The machine is constructed entirely of stainless steel for durability and easy cleanup.

### **Operation:**

Hot water is fed into the Berry Cascading Waterfall Reservoir and mixes with steam to create a cascade of water to scald the wings as the shackles travel through the waterfall. Water temperatures ranging between 120° and 180° are recommended for best results. Excess water can be recycled through methods such as a Berry Water Reuse Screen or Collection Tank to reduce water usage and cost.

### **Maintenance:**

With proper operation, the only maintenance the **Berry Single Sided Cascading Waterfall** requires is daily cleaning and checking of various parts such as the guide bars & hardware for wear and tear.

Specs are for the 10' model shown. Waterfall Units can be built to customer specifications for desired length.

The specifications as stated herein are the most current at the time of publication. However, consistent with our standard of continual product development, we reserve the right to change the design without notice or obligation to modify any equipment previously sold or delivered. 01/17/2012

### **Berry Plumbing & Equipment**

6736 Cleveland Highway, Clermont Georgia 30527

Email: [tberry@berryequipment.net](mailto:tberry@berryequipment.net)

Phone: 770-983-3929 Toll Free Fax: 1-866-808-9957

# Berry Single Sided Cascading Waterfall - Model B-CW-1-SS

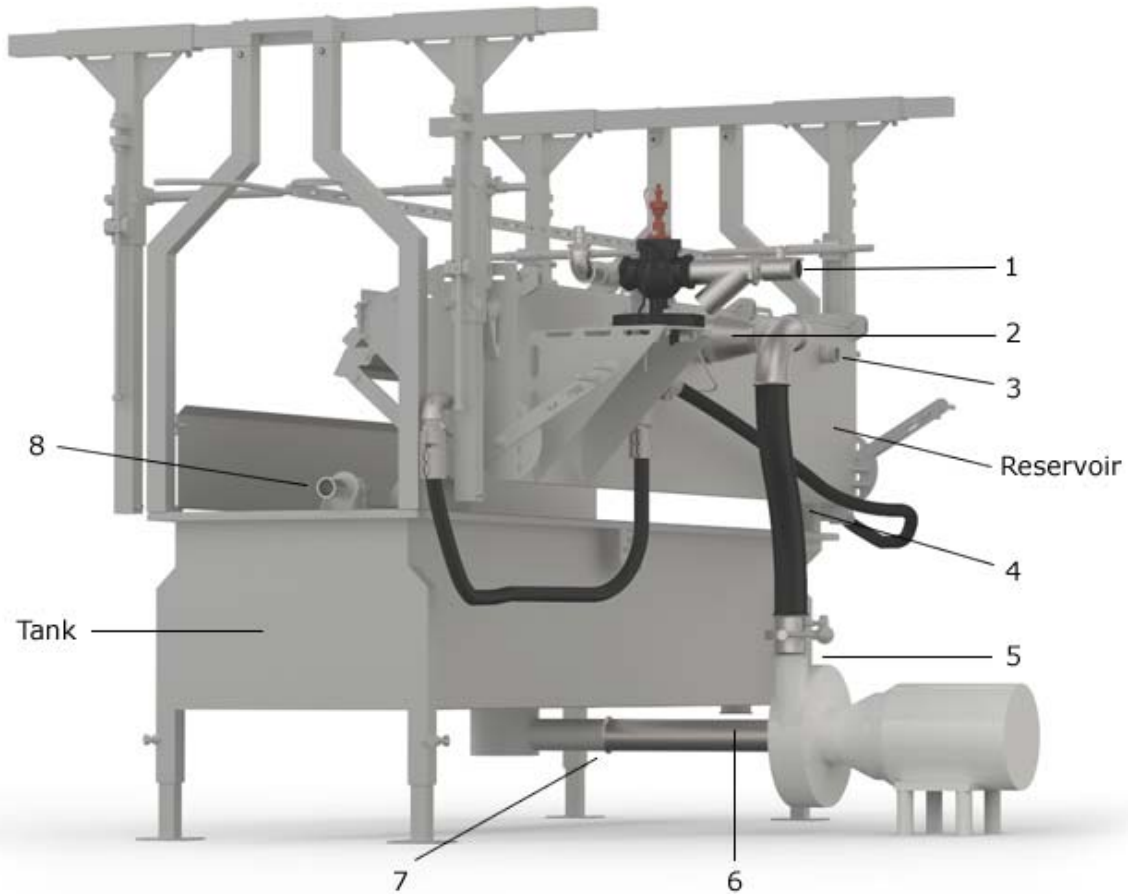

LOC	Connections
1	Steam Connection: 1-1/4" NPT
2	Reservoir Inlet: 6" Ferrule
3	Reservoir Hot Water Fill: 2" NPT
4	Reservoir Drain: 3" NPT
5	Pump Outlet: 4" Ferrule
6	Tank Drain: 4" Ferrule
7	Pump Inlet: 4" Ferrule
8	Tank Hot Water Fill: 2" NPT

The specifications as stated herein are the most current at the time of publication. However, consistent with our standard of continual product development, we reserve the right to change the design without notice or obligation to modify any equipment previously sold or delivered. 01/17/2012

**Berry Plumbing & Equipment**  
 6736 Cleveland Highway, Clermont Georgia 30527  
 Email: [tberry@berryequipment.net](mailto:tberry@berryequipment.net)  
 Phone: 770-983-3929 Toll Free Fax: 1-866-808-9957