

Berry/Emech Mixing Valve



◀ Emech temperature control solution

F3 mixing valve and G1 actuator with integrated temperature sensor

The 3 port valve uses a shear action ceramic disc providing fast response to pressure variability and allowing tight shutoff. The valve body incorporates a mix chamber to provide high performance mixing allowing the temperature probe to be placed in the valve at the point of mix. Available in Water Mixing and Steam-Water Mixing.

Berry / Emech Mixing Valve

emech

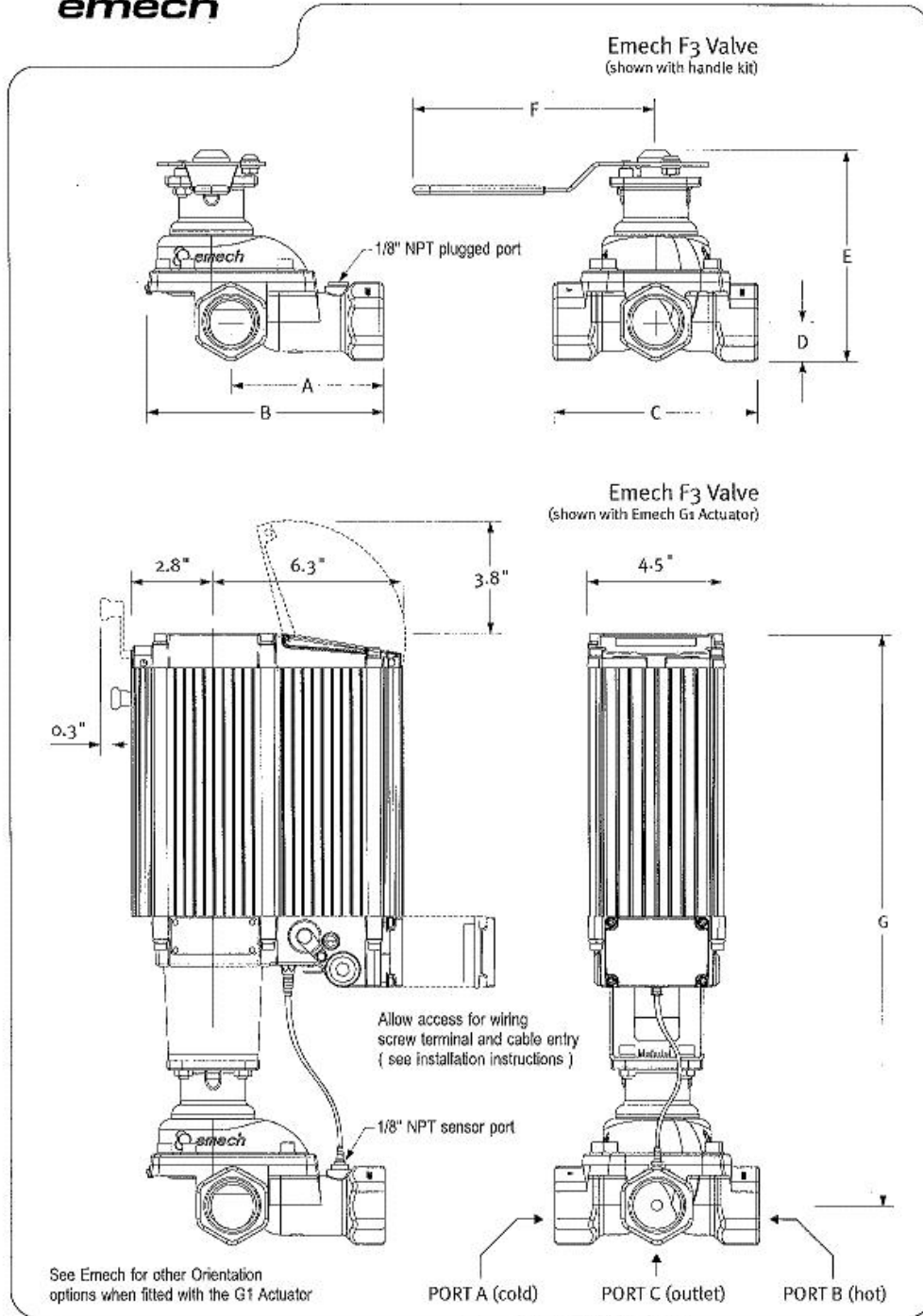

Assembly includes:

- Valve
- Actuator
- Software CD
- Serial Cable
- Temperature Probe
- Actuator Mounting Kit
- Gland Spanner
- Power Supply

Berry Plumbing & Equipment

6736 Cleveland Highway, Clermont Georgia 30527

Email: tberry@berryequipment.net

Phone: 770-983-3929 Toll Free Fax: 1-866-808-9957

Berry / Emech Mixing Valve

The Emech system presents a unique "out of the box" control solution ensuring that temperature accuracy can be maintained even during unequal pressure differentials.

- Controls output water temperature within +/-0.9° F regardless of input temperatures or pressures
- Valves available for water only or steam and water to fit most standard size lines
- Provides precise control over water temperatures for critical process and cleaning applications
- Increased accuracy of mixing has provided significant savings to customers in the form of reduced energy cost and improved process yields

WATER	Sized to fit application / 1", 1-1/2", 2"
ELECTRICITY	Regulated 24 V dc
CAPACITY	Minimum flow of 20 GPM
HEIGHT	20" APPROX (based on 1-1/2" valve size with G1 Actuator)
WIDTH	8" APPROX (based on 1-1/2" valve size with G1 Actuator)
DEPTH	10" APPROX (based on 1-1/2" valve size with G1 Actuator)

The specifications as stated herein are the most current at the time of publication. However, consistent with our standard of continual product development, we reserve the right to change the design without notice or obligation to modify any equipment previously sold or delivered. 12/31/2000

Berry Plumbing & Equipment

6736 Cleveland Highway, Clermont Georgia 30527

Email: tberry@berryequipment.net

Phone: 770-983-3929 Toll Free Fax: 1-866-808-9957