

## **Model BFPS3-24-LH/RH**

*US Patent #7625270 B2*

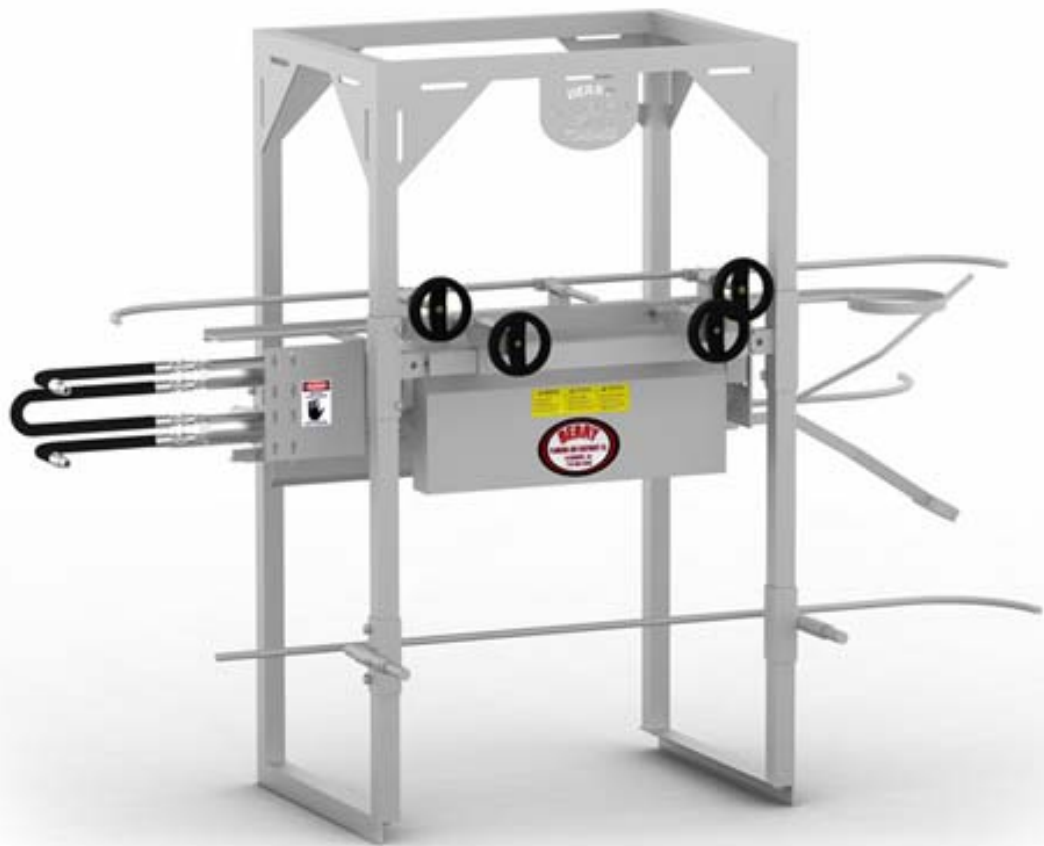

Automatically fed, hydraulically powered and designed to improve the appearance of the paws of all size birds lots, the Berry Foot Pad Scrubber, Model **B-FS3-24-LH/RH** from Berry Plumbing & Equipment will handle any line speed.

Berry Foot Pad Scrubber 3

## Berry Foot Pad Scrubber , Model B-FPS3-24

### **Construction:**

The Berry Plumbing & Equipment **Foot Pad Scrubber Model B-FS3-24-LH/RH** is constructed entirely of stainless steel and UHMW for durability and easy cleanup.

### **Operation:**

Automatically fed and hydraulically powered, the Berry **Foot Pad Scrubber Model B-FS3-24-LH/RH** matches the speed of your Overhead Conveyor. Installed after the scalding but before the hock cutter, the **Foot Pad Scrubber** features two brushes that massage the foot, assisting in removal of ammonia burns, cuticle, and even fecal matter.

### **Maintenance:**

With proper operation and regular cleaning, the only other maintenance the **Foot Pad Scrubber Model B-FS3-24-LH/RH** requires is lubrication of bearings..

### **Options:**

Berry Plumbing & Equipment offers a **Hydraulic Power Unit** for operation of the **B-FS3-24-LH/RH**. The Berry **Foot Pad Scrubber** is designed in this 36" model with 24" brushes (Model #BFPS3-24) and also available in the 60" model with 48" brushes (Model # BFPS3-48).

### **Hydraulic Brush Motors:**

2 per machine  
3 cubic inches  
1000 psi @ 5.5 gpm each motor  
RPM = 377  
Torque = 339 in/lb

- Port A of top motor—fluid in from plant
- Port B of top motor connects to port B of bottom motor
- Port A of bottom motor—fluid return to plant

## Berry Foot Pad Scrubber , Model B-FPS3-24

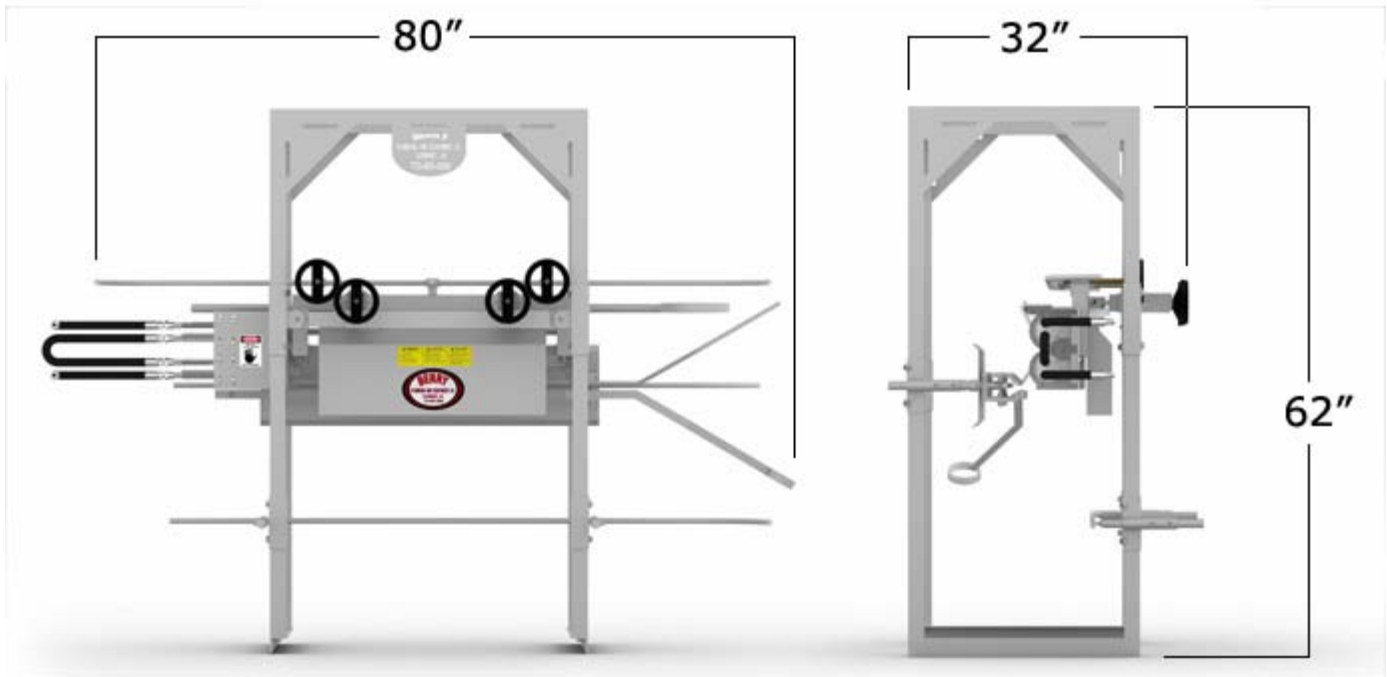

<b>HYDRAULIC FLUID:</b>	5.5 GPM
<b>PRESSURE:</b>	1000 PSI
<b>CAPACITY:</b>	DETERMINED BY LINE SPEED
<b>POSITION IN LINE:</b>	AFTER THE BIRD SCALDER PRIOR TO HOCK CUTTER
<b>FACING:</b>	DETERMINED FACING BACK OF BIRD (AVAILABLE IN LEFT HAND OR RIGHT HAND MACHINE)
<b>HEIGHT:</b>	62" APPROX.
<b>WIDTH:</b>	80" APPROX
<b>DEPTH:</b>	32" APPROX

The specifications as stated herein are the most current at the time of publication. However, consistent with our standard of continual product development, we reserve the right to change the design without notice or obligation to modify any equipment previously sold or delivered. 12/31/2000

### **Berry Plumbing & Equipment**

6736 Cleveland Highway, Clermont Georgia 30527

Email: [tberry@berryequipment.net](mailto:tberry@berryequipment.net)

Phone: 770-983-3929 Toll Free Fax: 1-866-808-9957